

## Technical data

	Metric	Imperial
Annular cutting	Ø 12 - 36 mm	Ø 7/16" - 1 7/16"
Twist drilling	Ø 1 - 13 mm	Ø 1/16" - 1/2"
Countersinking	Ø 10 - 40 mm	Ø 3/8" - 1 9/16"
Length	325 mm	12 13/16"
Width	235 mm	9 1/4"
Height	370 - 410 mm	14 9/16" - 16 1/8"
Stroke	140 mm	5 1/2"
Weight (incl. batt)*	10.2 kg	22.4 lbs
Magnet (l x w x h)	157 x 85 x 45 mm	6 3/16" x 3 3/8" x 1 3/4"
Magnetic force	650 kg	1,433 lbs
Min. material thickness	6 mm	1/4"
Motor power	1,000 W	
Total power	1,000 W	
Speed (no load)		530 rpm
Speed (load)		430 rpm
Spindle (Weldon)	19.05 mm	3/4"
Battery capacity	18 V 5 Ah Li-ion, 18 V 9 Ah Li-ion	

\* Without handles

## Features



Battery operated



Permanent magnet



Brushless motor



Makita LXT 18V platform



Magnet LED-indicator (SensorTec)

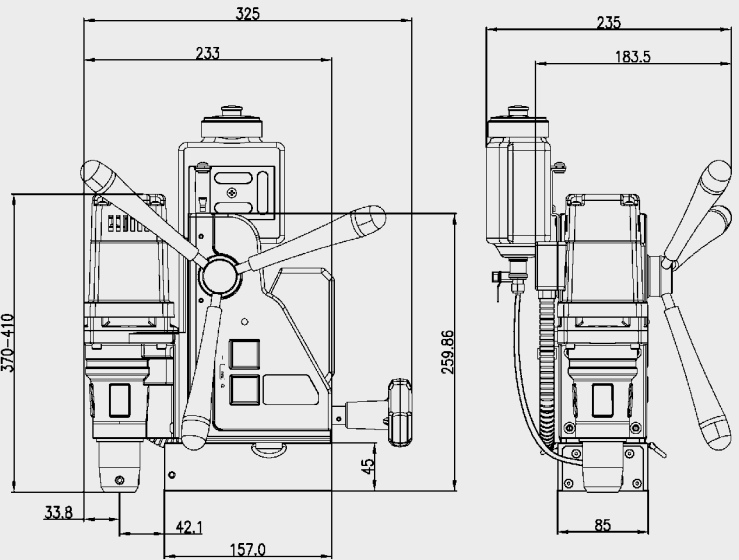

## Perceuse sur batterie KE36BAT



Euroboor makes every effort to meet quality and integrity requirements. That is why we as an organization are proud of the recognition of some leading organizations worldwide:

